

# Specification

**Product Name:** DC controller

---

**Product Model:** MC137D A&B

---

Versions	Release/ change Date	Reason	Publishing
V1.0	2023.02.14		James.Guo
V1.1	2023.03.22	Modify the description of the remote control	James.Guo
V1.2	2023.03.30	Update microwave antenna Installation Notice and Radiation Diagram	James.Guo
V1.3	2023.04.12	Modify the description of the remote control	James.Guo

## 【Product Features】

- Patented Miniature Coupled Pole Antenna
- Long strip shell, miniature antenna design, no shading
- Ultra-low RF power output, harmless to human health
- Support remote control and DIP switch to adjust sensing parameters
- Low side lobe, high adaptability to metal environment
- Not affected by temperature, humidity, noise, airflow, dust, light and other environments



## 【Model Selection】

0-10VDC dimming signal: MC137D A

PWM (dimming frequency 1KHz) dimming signal: MC137D B

## 【Function description】

- Switch function
- Two stage dimming function
- Three-stage dimming function
- Daylight harvesting
- Daylight priority function

## 【Diagram】

### ● Dimensions

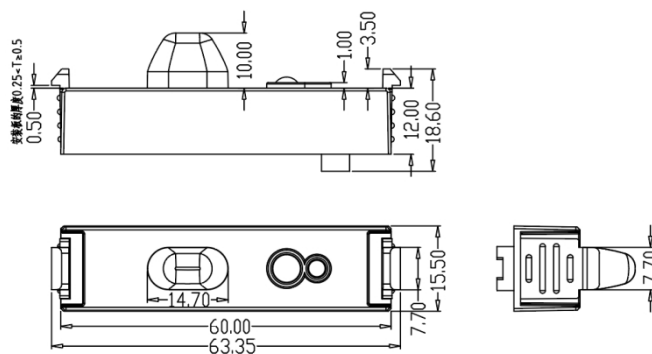

### ● Wiring Diagram, Function Diagram

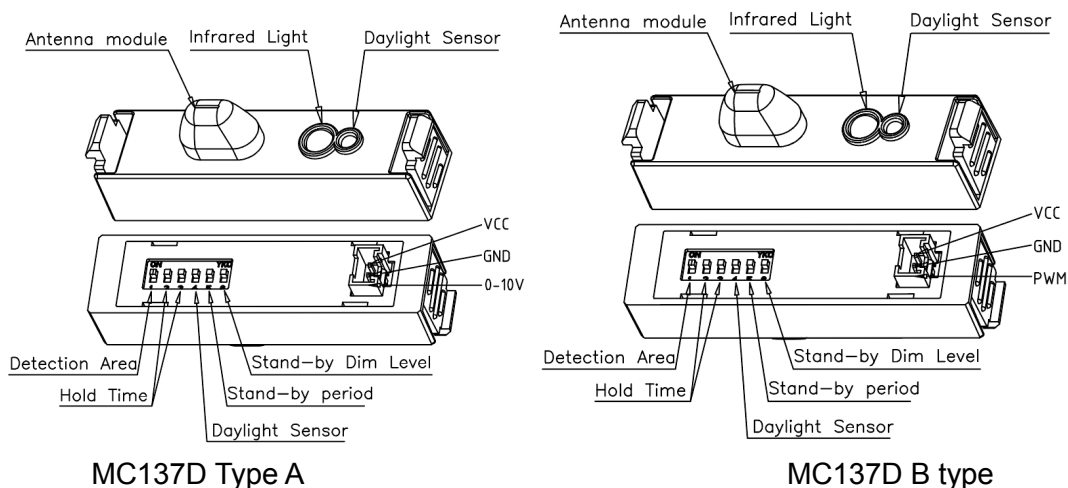

● Installation diagram

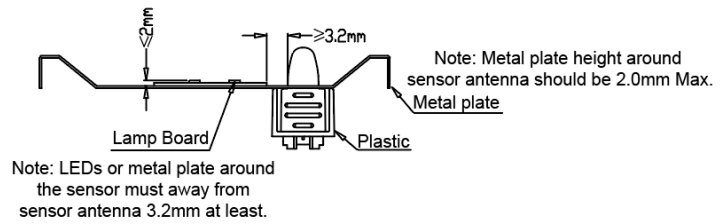
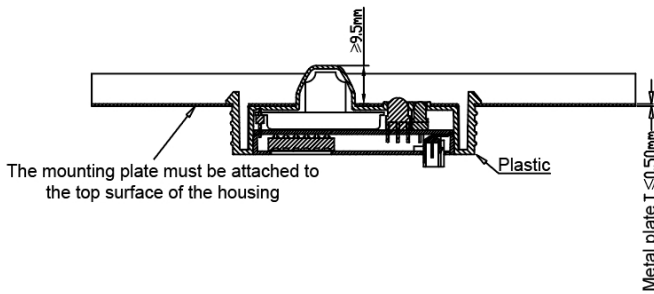
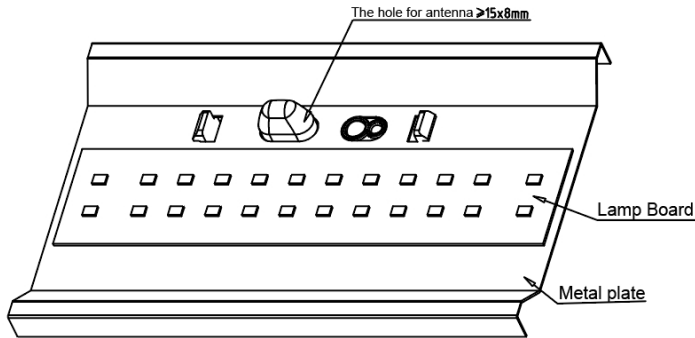
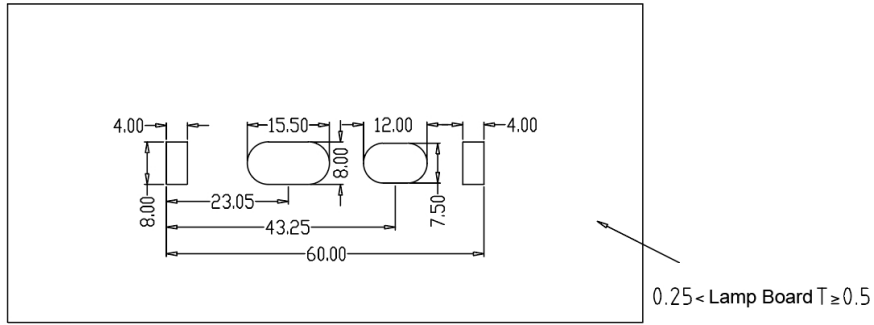

**Notice**

When installing, please pay attention to the distance between the microwave antenna and the light board.

## 【Parameter】

Input	
Rated voltage	12 ± 0.5VDC
Working current	16±2mA
Ripple voltage	< 100mVp-p
output	
output signal	<input checked="" type="checkbox"/> 0 -10VDC dimming signal MC137D Type A <input checked="" type="checkbox"/> PWM dimming signal MC137D B type
Sensor parameters	
working frequency	5.8GHz ±75MHz, ISM band
transmitting power	1mW Max.
Detection range (radius)	Ceiling installation 3m high: 0.3m/s ≥ 4m, 1m/S ≥ 3m; Horizontal installation 2m high: 0.3m/s ≥ 8m, 1m/S ≥ 4m Test conditions : the product is set to 100% sensitivity , and there is no obvious occlusion in the room of 60 m <sup>2</sup>
Installation height	3m ( 6m Max )
3db beam angle	90 °@XZ plane 85 °@YZ plane
Environment	
Working temperature	Built-in: 25T70
Storage temperature	-40℃…80℃, humidity ≤85% (non-condensing)
Certification standards	
Certified	CE , RED
Environmental requirements	Comply with RoHS 2.0 , Reach requirements
IP Rating	IP 2 0
Other	
Wiring	3pin 2.0mm terminal
installation requirements	built-in installation
packaging requirements	Bubble bag + partition + outer box (K=A)
net weight	10±2g
lifetime	5 Years Warranty@Ta

## 【DIP Switch setting】

Toggle up the DIP Switch to "ON"

Downwards to "L"

Detection Area			Hold Time			Daylight Sensor		Stand-by DIM level		Stand-by Period	
1	2	Detection Radius	2	3	5S	4	5	0%	20%	6	+∞
–	100%	Around 3 meters	–	–	5S	–	Disable	–	0%	–	+∞
ON	50%	Around 1.5 meters	ON	–	3min	ON	30Lux	ON	20%	ON	15min
			ON	ON	10min						

● radiation diagram

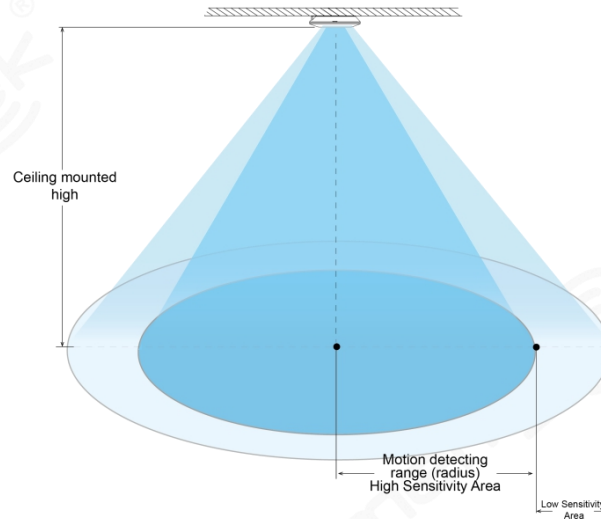

**【Remote Control Instructions】**

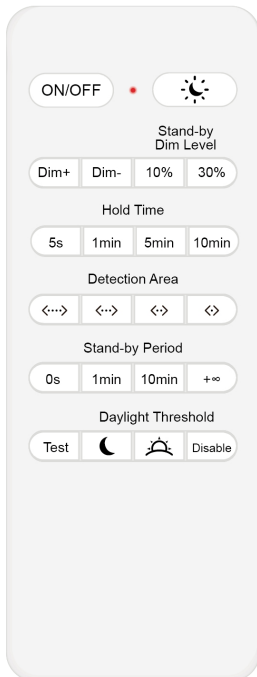

Button	Function	Description
ON/OFF	Normal ON/OFF	Pressing the ON/OFF button, sensing function is canceled and the light will remain ON/OFF. Sensor has power-off memory function, that is: pressing this button, the sensing function is still canceled after power off, and the light remains brightness (the last setting). The sensing mode can be restored by pressing the 'Detection Area' button, and then the sensor will be perform this sensitivity (Other paramerers stay the latest setting)
	Night light function	Short Press- this button, the light will maintain 10% brightness. Long press 3s to reset sensor, the light will maintain 100% brightness, and all parameters are same as setting of DIP switch. In night light mode, Dim+ / Dim- is still available. The light remains brightness (the last setting) after power on again. The sensing mode can be restored by pressing the 'Detection Area' button, and then the sensor will be perform this sensitivity (Other paramerers stay the latest setting)
Dim+	Increasing Brightness	Pressing this button continuously, the brightness will increase 5%. ON mode is still available. Dimming range: 30%-100%
Dim-	Reducing Brightness	Pressing this button continuously, the brightness will reduce 5%. ON mode is still available. Dimming range: 30%-100%
Stand-by Dim Level	Low Brightness	10%, 30%
Hold Time	100% Brightness	30s, 1min, 5min, 10min
Detection Area	Detection Area	100% <---> , 75% <-> , 50% <-> , 25% <>
Stand-by Period	Stand-by Time	0s, 1min, 10min, +∞
Test	TEST Button	Pressing this button, the light will turn off after 2 seconds. Restore to last sensing setting after power off.
Daylight Threshold	Threshold	15lux  , 50lux  , Disable

**【Initialization】**

The sensor will turn on the light at 100% brightness for the first time, and turn it off after 10 seconds. During the initialization period, sensor is not able to detect the movement.

## 【Default setting】

Sensitivity: 100% Hold Time: 5 s Daylight Threshold: Disable Stand-by period: +∞ Stand-by Dim level: 0%

## 【Application Notice】

- The sensor should be installed by a professional electrician. Please cut off the power before installing, wiring, changing the setting of the dial switch, etc.
- The sensing distance is related to factors such as the moving speed of the moving object, the size of the moving object, the installation height, the installation angle, whether the installation environment is open, and the material of the reflector. The detection distance given in the specification is a typical value, which is 165cm/65kg tester, and it is tested in an open indoor environment
- When the microwave sensor is installed on the wall, the detection distance will be greatly increased compared with that installed on the ceiling. If you use the wall installation method, please reduce the sensitivity to use or contact our company to confirm the use setting. The light sensitivity threshold is in a sunny environment, no shadows, and ambient light diffuse reflection conditions. In different time periods, climates, and environments, the illuminance value detected by the light sensor may be different
- Sensor parameters may need to be reconfigured in different installation environments, please refer to the following instructions or contact the manufacturer
- This sensor is only for indoor use, outdoor wind and rain, and surrounding moving objects will cause false triggering
- The installation height of the sensor product cannot exceed 6 meters, and the optimal height is 3 meters; the distance between the two sensors should be greater than 3 meters
- When the sensor is installed in a metal lamp, on a metal reflective surface, or in a narrow closed environment, microwaves will be reflected multiple times and cause false triggering. Please reduce the sensor sensitivity or contact the manufacturer for technical support.
- Please make sure that there are no moving signals such as fans, DC motors, sewer pipes, air outlets, etc. around the sensor, otherwise the sensor may cause false triggering.
- Microwaves cannot penetrate metal, avoid installing in closed or semi-closed metal lamps, and there should be no metal or glass blocking the product
- Sensor with different PWM / 0-10V driver, low light effect may be different
- A DC regulated power supply with stable output voltage and low ripple coefficient must be used. The ripple of the power supply should be less than 100mV ; the load current should be greater than 35 mA
- Product specifications and parameters may be optimized without prior notice